

# PLC Based Intelligent Traffic Control System

Muhammad Arshad Khattak

*Department of Computer Science and Information Technology  
Sarhad University of Science and Information Technology (SUIT)  
Peshawar 25000 Pakistan  
[arshad.csit@suit.edu.pk](mailto:arshad.csit@suit.edu.pk)*

## ABSTRACT

The main object of this study was to design and implement intelligent traffic control system. The system developed is able to sense the presence or absence of vehicles within certain range by setting the appropriate duration for the traffic signals to react accordingly. By employing mathematical functions to calculate the appropriate timing for the green signal to illuminate, the system can help to solve the problem of traffic congestion. Hardware simulation tests were successfully performed on the algorithm implemented into a PLC (programmable logic controller).

The new timing scheme that was implemented promises an improvement in the current traffic light system and this system is feasible, affordable and ready to be implemented especially during peak hours, off hours and pedestrians.

The PLC checks the status of the sensors. The system resolution is depend on the output provided by the sensors , Then PLC checks the priorities and then provide output signal to the traffic lights poles for ON or OFF the Red, yellow or Green lights and ON time is depend on the specific priorities. The roads are opened in that manner that east road, west road, north road and then south road is open.

## 1. INTRODUCTION

Traffic load is highly dependent on parameters such as time, day, season, weather and unpredictable situations such as accidents, special events or construction activities. If these parameters are not taken into account, the traffic control system will create bottlenecks and delays. A traffic control system that solves these problems by continuously sensing and monitoring traffic conditions and adjusting the timing of traffic lights according to the actual traffic load is called an intelligent traffic control system.

Traffic control systems may also be classified as saturated or unsaturated, depending on whether they were designed for a saturated or unsaturated network. In an unsaturated network, it is desired to minimize the mean delay of drivers, while in a saturated network it is desired to serve as many drivers as possible, or in other words, to maximize traffic capacity of the intersection. The problem of capacity maximization is the same as the queue minimization problem

The older system uses weight as a trigger mechanism. Current traffic systems react to motion to trigger the light changes. Once the infrared object detector picks up the presence of a car, a switch causes the lights to change.

An adaptive traffic control system must have the ability to diagnose saturation conditions in the network and change the objective function as desired. In older fixed-time systems, there were multiple timing plans, but now a modern traffic control system can have multiple control strategies.

We need to understand the function of traffic signals so that we can improve driving habits by controlling the speed in order to reduce the number of associated traffic accidents. The more number of drivers

who know about the operation of traffic signals, the less frustrated they are going to be while waiting for the lights to change. The main aim in designing and developing of the Intelligent Traffic Signal Simulator is to reduce the waiting time of each lane of the cars and also to maximize the total number of cars that can cross an intersection given the mathematical function to calculate the waiting time.

The Intelligent Traffic signal Control System consists of three important parts. The first part is the PLC controller and second part is hardware. These usually comprise of red, yellow, and green lights. The third part is the sensor. The sensors check the presence of vehicles.

## 2. OVERVIEW OF PLC BASED ITCS

The main theme of this report is to build and verify the designs and understand the concept. The main objective is to build a hardware device that has:

1. The ability to collect the information of the busy tracks by sensors and providing the output to PLC.
2. The ability to take decision against the information and change the time according to the priorities.

### 2.1 Traffic Control System

- Traffic signals control vehicle movements
- Traffic Control Systems are interconnected with electronics system that controls traffic signals.
- Traffic Control Systems depend on logic which can be divided into these categories:
  - i. The signal phases and cycle length are depend on the traffic flow on the desired track
  - ii. The system responds to interrupts or timing base system and open the desired signal according to the priority requirement

### 2.2 Advantages

Traffic signals help control the flow of vehicles, pedestrians and bicycles by giving "right-of-way" to the various movements in an orderly manner. Signals that are properly located, designed and maintained can:

- Provide for orderly movement of traffic.
- Increase capacity of the intersection.
- Reduce frequency and severity of certain types of crashes, especially right-angle collisions.
- Provide for continuous movement of traffic at a definite speed along a given route.
- Interrupt heavy traffic at intervals to permit other vehicles or pedestrians to cross.
- Effectively perform traffic management
- Overall, traffic signals help us get where we're going safely and in a timely manner.

### 2.3 Disadvantages

Traffic signals are sometimes considered problems at intersections. In fact, traffic signals that are poorly located can adversely affect the safety and efficiency of vehicle, bicycle and pedestrian traffic. Improper or unjustified signals can result in one or more of the following:

- Significant increase in the frequency of some types of collisions
- Increased congestion, air pollution, and fuel consumption.
- Excessive delay.
- Excessive disobedience of the signal indications.
- Increased use of less adequate streets as motorists attempt to avoid the traffic signals.
- Frustration especially in hot weather.

### 2.4 What is Intelligent Traffic Control System (ITCS)?

An Intelligent Traffic Control System senses the presence or absence of vehicles and reacts according to the sensors output. In this system PLC takes a data from sensors and checks the priorities. After that PLC provides signal to traffic signals.

The intelligent traffic control system works in four different modes are Normal flow, peak time, off time and manual operation. Peak time and off time modes are depended on the sensors outputs then change the status. Our intelligent traffic control system totally depend on the sensors output and take decisions.

### 2.5 Study overview

This study has two main parts. First is study of PLC and the second part is its application intelligent traffic control system. The intelligent traffic control system has further divided into two main parts, Programming and hardware. Ladder logic Programming technique is used. PLC T100MD2424+ is used for attaching with proto type hardware. In hardware photoelectric sensors is used for sensing the presence the vehicles on the square in proto type.

### 2.6 What is PLC?

A PLC (Programmable Logic Controller) is a device that was invented to replace the necessary sequential relay circuits for machine control. The PLC works by looking at its inputs and depending upon their state, turning on/off its outputs. The user enters a program, usually via software, that gives the desired results

### 2.7 Practical System Design

Practically Inductive Loops are used as sensors to detect the presence of vehicles on intersections. Its basic function is to provide interrupts to controller unit. It has two parts, first is coil and second is the detector unit. Coil is a main part of a sensor and consists of one or more loops of wire embedded in the pavement.

This inductive coil is connected with the detector unit, which is an electronic circuit. When vehicles passes over or rests on the inductive loop then due to induction on vehicle more current flow through inductive loop and this change of current also changes frequency. Detector unit can detect these changes. Finally, detector unit sends an interrupt signal to controller unit.

### 2.8 Prototype Hardware

In prototype design Photo electric sensors are used, for prototype it is not possible to design an induction loop. As the basic function of

induction loop in Intelligent Traffic Control System is used to provide an interrupt signal to controller unit. We use Photo electric sensors rather than induction loops. In our design, photo electric sensors provide an interrupt signal to controller unit. In case when vehicle reaches in front of sensors, then it provides an interrupt.

### 2.9 flow diagram of traffic

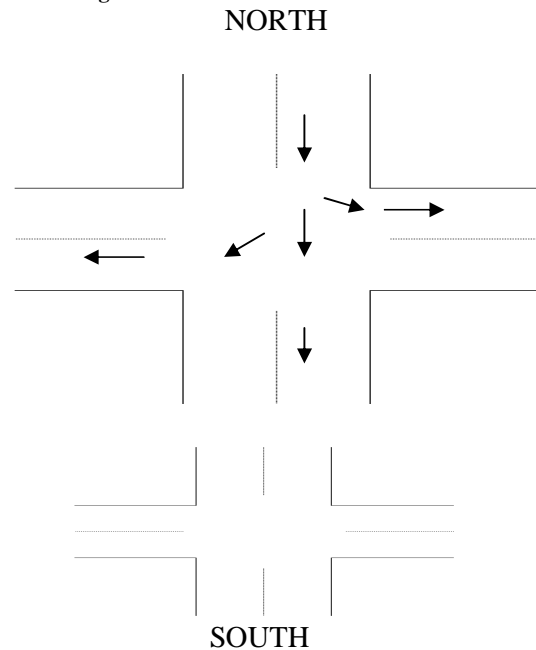

### 2.10 System block diagram

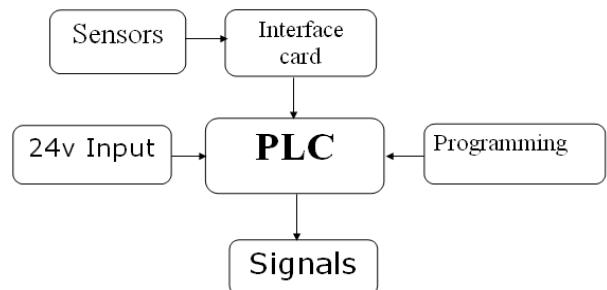

## 3 SIMULATION

### 3.1 Tool

TRILOGI software has built in simulator engine. It is used without attaching the PLC hardware. This is the main advantage of the TRILOGI software. This type of feature is not used in other software

### 3.2 Advantages of TRILOGI software

The main advantage of the TRILOGI software has it's built in simulator engine that provide us the facility to simulate the program any time without attaching the plc module. We check our all priorities, inputs, interrupts, timers, relays, counters and its output status in live condition. This is the big advantage of TRILOGI software.

### 3.3 PLC simulator

- Trilogi has built in simulator engine which is in effect a "soft PLC"
- Great ease of program testing and debugging

- Test run of program off-line directly on the same pc that runs TRILOGY
- Program can be distributed amount students to run that at home and test their logics without the need of PLC
- Remotely program, monitor, control and troubleshoot your super PLC controlled equipment via the internet at any time
- Remote software update
- PLC can e-mail specific reports at required time
- PLC can send SMS with just a single line of code

## 4 HARDWARE IMPLEMENTATION

### 4.1 Hardware Components

1. PLC T100MD module
2. Interface card
3. Photoelectric Sensors
4. Signal poles
5. Communication Ports
6. Toggle Switches
7. Proto type hardware

### 4.2 PLC T100MD module

T100MD2424+ is a new member of the highly popular T100MD PLC family. The basic unit comprises 8 analog I/Os, 24 digital Inputs and 24 digital outputs. Two of the digital outputs (7 & 8) which can be also defined as PWM outputs can each deliver up to 10A peak and 2A continuous, 24VDC (active high) current to the load. The 8 analog I/Os are configurable as 8 AI, no AO or 6 AI and 2 AO. All analog inputs are 10-bit resolution and all analog outputs are 8-bit resolution.

T100MD2424+ is expandable up to a total of 96 digital inputs and 96 digital outputs with an optional expansion module. It has an RS232 and an RS485 port. Both of them are conversant in MODBUS protocol. The built-in LCD port allows simple interface to industry-standard LCD modules from 8 characters to 80 characters.

The compactly designed T100MD2424+ PLC can be easily installed in many kinds of plastic or metal enclosures. You need to use 4 or 5 PCB standoffs (or some screws and nuts) to support the controller and fasten it to a console box.

Analog I/O Ports: The 8 channels of analog I/Os are available via an 8-way detachable screw terminal connector along the left edge of the T100MD2424+ PLC. The PLC also supplies a +5V analog reference-voltage output

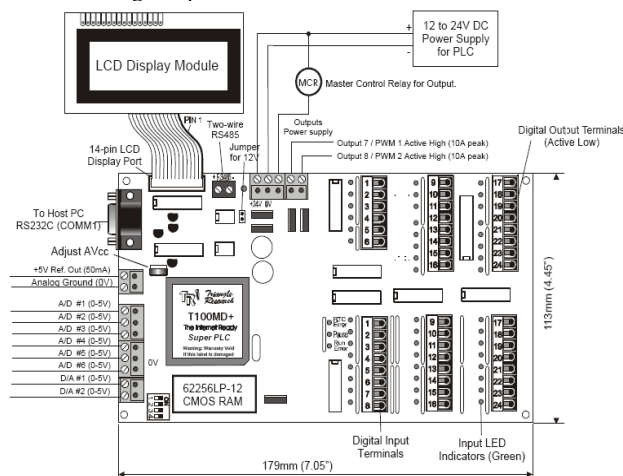

Digital I/O Ports: Detachable screw terminals are provided for quick connection to all digital inputs, outputs and power supply wires. Each block of screw terminals can easily be detached from the controller body, enabling easy replacement of the controller board when necessary. Since the terminal block for digital I/Os are inserted vertically to the board surface, you need to remove the terminal block before you can start wiring. Use a small flat-head screwdriver and insert underneath the terminal block, apply even pressure to raise the terminal block until it becomes loosened from the connecting-pin strip, as shown below:

Although wires of up to 24 AWG may be connected directly to the screw terminal, insulated crimp ferrules should be used to provide a good end termination to multithreaded wires. Use of ferrules reduces the possibility of stray wire-strands short circuiting adjacent terminals and their use is therefore highly recommended.

The T100MD2424+ PLC requires a single regulated, 12 to 24V (+/- 5% ripple) DC power supply for the CPU and I/Os (as shown in Figure 1). It is recommended that whenever possible, use a higher power supply voltage since the voltage difference between ON and OFF state is wider for operation at higher voltage. To use the T100MD2424+ at 12VDC you should place a jumper block on the two-pin header marked "J1-12V" near the power supply terminals.

You must remember to remove the jumper when operating the PLC above 18V. Otherwise the voltage regulator may overheat. Please use only industrial grade linear or switching regulated power supply from established manufacturers. Using a poorly-made switching power supply can give rise to a lot of problems if the noisy high frequency switching signals are not filtered properly.

If your application demands very stable analog I/Os you should choose a linear power supply instead of a switching power source for the CPU. Always place the power supply as near to the PLC as possible and use a separate pair of wire to connect the power to the PLC. Keep the power supply wires as short as possible and avoid running it along side high current cable in the same cable conduit. The T100MD-2424+ PLC will be reset when the power supply voltage dips.

### 4.3 Interface card

The interface card is used between the sensors output and PLC for interfacing. In this card we use opto coupler is used for short the two pins i.e. pin # 1 and pin # 25. When the input is approaches from sensor then a current limiting resistor is used for reducing the current and drops the voltage for a specific limit.

When sensors provide output then a resistor is used in series with the opto coupler and the output terminal of the opto coupler is attached with pin no 1 and lower terminal is connected with pin no 25. When the opto coupler gains supply at its input then the output terminal is short and behaves like a switch, so PLC receive a interrupt from pin no 1 and than take decision about that.



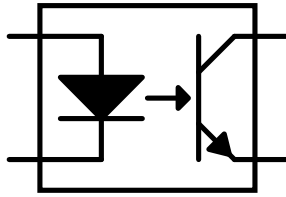

Symbol of opto coupler



Interface card

We use single opto couplers for each input with a resistor and use 8 inputs that represent 8 sensors. These opto couplers are connected from pin # 2 to pin # 9.

### 4.3 Photoelectric Sensors

We use photo electric sensors for sensing the presence of the vehicle on the road. We use industrial based sensors has variable range that can be adjust by a variable knob at its surface. It has built in transmitter and receiver. This sensor works on PNP condition means that when object is placed in the range of sensor then it provides output. It has 3 output wires, one is used for input supply, and second wire is common between input and output. Third wire is used as output when object is detected.

#### 4.3.1 Inductive Loops (Practical System)

Loop detector technology has become the most widely used sensor in incident detection systems. They are capable of measuring flow and occupancy, and estimating vehicle speed. They can also be used to actuate traffic control devices and detect congestion and incidents.

An inductive loop detector consists of one or more loops of wire embedded in the pavement and connected to a control box, excited by a signal ranging in frequency from 10 KHz to 200 KHz. When a vehicle passes over or rests on the loop, the inductance of the loop is reduced showing the presence of a vehicle.

The raw data supplied by inductive loop detectors are vehicle passage, presence, count, and occupancy. For incident detection, loop data is usually relayed to a controller for analysis.

### 4.4 Signal Poles

It is a device that indicates the status of the signal. The purpose of signals poles to ON or OFF lights (Red, Yellow, and Green). Its timing depends on the input given by the PLC according to the timing of the programming priorities. One signal open at a time and all other signals are stopped. Each signal light is a combination of four LEDs, two are connected in series and two are connected in parallel.

### 4.5 Communication Ports

The latest revision (Rev. D or D-1) of the T100MD+ features two independent serial ports that can simultaneously communicate with other devices using a variety of protocols. They can also be programmed to accept or send ASCII or binary data using the TBASIC built-in commands such as INPUT\$(n), INCOMM (n), PRINT #n, OUTCOMM n, d

The first serial port (COMM1) is an RS232C port which is compatible with most PC RS232C ports. The second serial port (COMM3) is a two-wire RS485 port that allows multiple PLCs to be connected to a single host computer or a master PLC for networking or to implement a distributed control system.

### 4.6 Proto type of Intelligent Traffic Control System

In this system black color shows the road and white dashes shows the separation between the two way traffic. The black poles basically the signals poles heaving Red, Yellow and Green LEDs for showing the signals. In the figure Blue color rod basically the photoelectric sensors that checks the presence of the vehicle. Each row has two sensors, first sensor is placed near the signal pole and the second sensor is placed away from the first sensor. We use total eight sensors for our system. The model of our design is shown

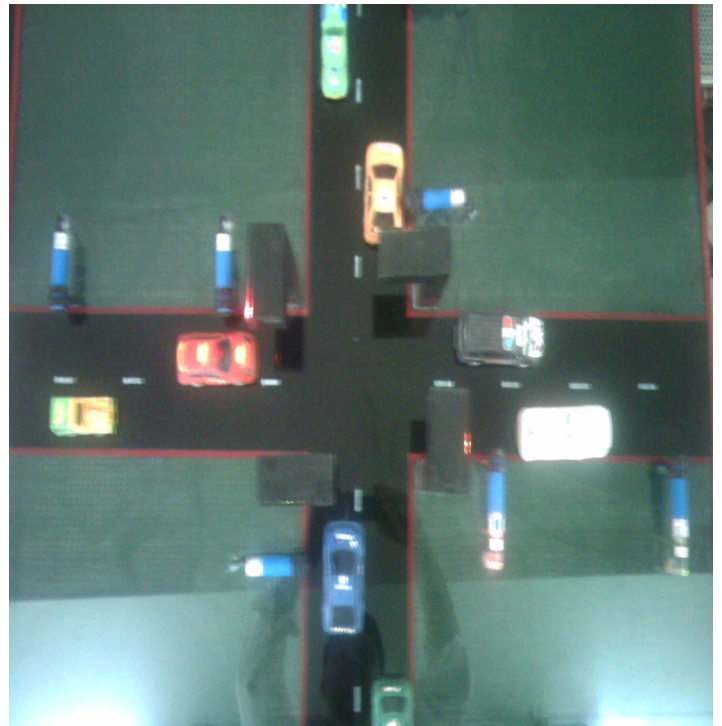

Proto type of intelligent Traffic Control System

### CONCLUSION

An intelligent traffic light system had successfully been designed and developed. The sensors were interfaced with Lab PLC Module. This interface is synchronized with the whole process of the traffic system. This prototype can easily be implemented in real life situations. Increasing the number of sensors to detect the presence of vehicles can further enhance the design of the traffic light system. Another room of improvement is to have the infrared sensors replaced with an imaging system/camera system so that it has a wide range of detection capabilities, which can be enhanced and ventured into a perfect traffic system.

### ACKNOWLEDGMENTS

While submitting this report I would like to gratefully acknowledge the kind support and able guidance provided to me through out my life by my father Late Master Abdul Khanan.

### REFERENCES

1. Alan J Crispin, 1997, "Programmable Logic Controller and their Engineering applications", second edition.
2. John W. Webb and Ronald A. Reis, "Programmable Controller, Principles and application".
3. Neil M. Schmitt and Robert F. Farwell, "Understanding Automation System".
4. W. Bolton, 2000, "Programmable Logic Controllers". Second edition.
5. Solomon, S., 1999. Sensors Handbook. McGraw- Hill, New York.
6. A.A. M.A. A. M. HIRARI. Et al. (2006), "Design and Development of sensor based traffic light system." American Journal of Applied Sciences 3: 1745, 1749.