

# Review of Research on Vehicles Aerodynamic Drag Reduction Methods

Mohd Nizam Sudin<sup>1</sup>, Mohd Azman Abdullah<sup>1</sup>, Shamsul Anuar Shamsuddin<sup>1</sup>, Faiz Redza Ramli<sup>1</sup>, Musthafah Mohd Tahir<sup>1</sup>

<sup>1</sup>Center for Advanced Research on Energy (CARE), Faculty of Mechanical Engineering, Universiti Teknikal Malaysia Melaka (UTeM), Hang Tuah Jaya, 76100 Durian Tunggal, Melaka, Malaysia.  
E-mail: nizamsudin@utem.edu.my

**Abstract--** Recent spikes in fuel prices and concern regarding greenhouse gas emissions, automotive design engineers are faced with the immediate task of introducing more efficient aerodynamic designs vehicles. The aerodynamic drags of a road vehicle is responsible for a large part of the vehicle's fuel consumption and contribute up to 50% of the total vehicle fuel consumption at highway speeds. Review on the research performance of active and passive flow control on the vehicle aerodynamic drag reduction is reported in this paper. This review intends to provide information on the current approaches and their efficiency in reducing pressure drag of ground vehicles. The review mainly focuses on the methods employed to prevent or delay air flow separation at the rear end of vehicle. Researches carried out by a number of researchers with regard to active and passive flow controls method on vehicle and their effect on aerodynamic drag in terms of drag coefficient ( $C_D$ ) was highlighted. Passive methods i.e. Vortex Generator (VG), spoiler and splitter and active flow controls i.e. steady blowing, suction and air jet are among the methods had been reviewed. In addition several attempts to couple these flow control methods were also reviewed. Several aspects of aerodynamic drag that need for further investigation as to assist for vehicles aerodynamic design and for practical reasons were highlighted. Progressive research on active flow control was observed due to its flexibility for wide range of application without body shape modification.

**Index Term--** Aerodynamic drag, drag coefficient, active control, passive control, vehicle aerodynamic

## 1. INTRODUCTION

The rapidly increasing fuel prices and the regulation of green house gasses to control global warming give tremendous pressure on design engineers to enhance the current designs of the vehicle using the concepts of aerodynamics as to enhance the efficiency of vehicles [1]. Fuel consumption due to aerodynamic drag consumed more than half of the vehicle's energy. Thus, the drag reduction program is one of the most interesting approaches to cater this matter. Aerodynamic drag consists of two main components: skin friction drag and pressure drag. Pressure drag accounts for more than 80% of the total drag and it is highly dependent on vehicle geometry due to boundary layer separation from rear window surface and formation of wake region behind the vehicle. The location of separation determines the size of wake region and consequently, it determines the value of aerodynamic drag. According to Hucho [2], the aerodynamic drag of a road vehicle is responsible for a large part of the vehicle's fuel

consumption and contributes up to 50% of the total vehicle fuel consumption at highway speeds. Reducing the aerodynamic drag offers an inexpensive solution to improve fuel efficiency and thus shape optimization for low drag become an essential part of the overall vehicle design process [3]. It has been found that 40% of the drag force is concentrated at the rear of the geometry [4].

Flow separation control is of major interest in fundamental fluid dynamics as well as in various engineering applications [1-56]. Numerous techniques have been explored to control the flow separation either by preventing it or by reducing its effects. These methods range from the use of passive to active control devices either steady or unsteady (e.g. synthetic jets, acoustic excitation). Among the various strategies employed in aerodynamic control, conventional passive control techniques, consisting in modifying the shape of the vehicle or attaching add-on devices to reduce the aerodynamic drag, appears as the easiest to implement but unfortunately it only dedicated for particular application. Due to wide range of applications active flow control is preferable. Thus research efforts are now focusing on active flow control techniques as an alternative to conventional design-modification solutions.

## 2. IMPACT OF AERODYNAMIC DRAG ON FUEL CONSUMPTION

Sudden spike in fuel prices and concern of greenhouse gas emissions, automotive design engineers are facing a new challenge for introducing more aerodynamic design vehicles. The ineffective aerodynamic shape results in excessive drag which leads to increased fuel consumption rates. The main cause of vehicle aerodynamic drag is due to pressure drag or form drag. Pressure drag on vehicles due to flow separation constitutes more than 80% of the total aerodynamic drag [5], while frictional drag constitutes for the remaining 20%. Thus, reducing aerodynamic drag is significant for the fuel consumption efficiency. In United States, the ground vehicles consumed about 77% of all (domestic and imported) petroleum; 34% is consumed by automobiles, 25% by light trucks and 18% by large heavy duty trucks and trailers. It has been estimated that 1% increase in fuel economy can save 245 million gallons of fuel per year. Additionally, the fuel consumption by ground vehicles accounts for over 30% of CO<sub>2</sub> and other greenhouse gas (GHG) emissions. Moreover, most of the usable energy from the engine goes into

overcoming the aerodynamic drag (53%) and rolling resistance (32%); only 9% is required for auxiliary equipment and 6% is used by the drive-train. 15% reduction in aerodynamic drag at highway speed of 55mph can result in about 5–7% in fuel saving [6]. Thus, research on vehicles aerodynamic drag reduction have been carried out for a few decades

### 3. ACTIVE FLOW CONTROL

Based upon whether the methods consume energy to control the flow or not, they are classified into active or passive control methods. Active control is performed by using actuators that require a power generally taken on the principal generator of energy of the vehicle. The visible part of these systems includes mobile walls, circular holes or slots distributed on the vehicle surface where the flow must be controlled. Their use requires mechanical, electromagnetic, electric, piezoelectric or acoustic systems placed in the hollow parts of the vehicle. Their weights and their overall dimensions must be smallest as possible to reduce their impacts on consumption and habitable volume. Several control solutions have been identified, tested and analyzed for aeronautics. It has been the same for the hydrodynamic and the aerodynamic of the road vehicles. The adopted solutions generally consist on suction or blowing systems through circular or rectangular slots. The suction and blowing can be continuous or intermittent [7].

#### 3.1 Active flow control with air jets

A large contribution to the aerodynamic drag of a vehicle arises from the failure to fully recover pressure in the wake region, especially on square back configurations. A degree of base pressure recovery can be achieved through careful shape optimisation, but the freedom of an automotive aerodynamicist to implement significant shape changes is limited by a variety of additional factors such styling, ergonomics and loading capacity. Active flow control technologies present the potential to create flow field modifications without the need for external shape changes and have received much attention in previous years within the aeronautical industry and, more recently, within the automotive industry. Bideaux et al. [8] performed experimental studies in a wind tunnel to control the flow separation on rear window of a generic vehicle shape (the Ahmed body with a scale of 0.7 and a slope angle of 35°). The rear part of Ahmed body was modified by changing the sharp edge between roof and rear window with smooth curved surfaces. This model was equipped with a strip of pulsed jets at the end of the roof to control the flow at a velocity of 30 m/s based on a periodical blowing. A maximum of 20% drag reduction was obtained with a pulsed frequency at 500 Hz and a momentum coefficient  $C_{\mu} = 2.75 \times 10^{-3}$ . This result confirms the significant of pulsed jets in reducing aerodynamic drag of vehicle.

A typical synthetic jet actuator consists of a jet orifice or slot opposed on one side by an otherwise sealed cavity and flush mounted on the other side to a fluid dynamic surface.

Time-periodic changes in the volume of the cavity are brought about by some mechanism such as an oscillating piston or a piezoelectric diaphragm (Fig. 1). These changes in volume of the cavity cause alternate expulsion and ingestion of the fluid across the slot with zero net mass flux (ZNMF). This process is often accompanied by the generation of a stream of vortices at the edges of the orifice/slot which impart finite momentum and vorticity into the surrounding fluid. Interaction of these vortical structures with the external flow field can trigger instabilities and enhance mixing in the external flow [9].

A number of numerical simulations of synthetic jet flows have also been reported in the literature. Kourta and Leclerc [10] applied the synthetic jet flow control on a road vehicle wake flow. The experiments were conducted in a wind tunnel using Ahmed body scaled at 0.7 of the original size. Synthetic jet actuator (Fig. 2) was developed by using electromechanical analogy with the help of the Lumped Element Modelling. The aerodynamic efficiency of the drag control was analyzed for different Reynolds numbers, Drag reduction up to 8.5% was attained at  $Re = 1.2 \times 10^6$  with a rear window tilted at 25°. Bellman et al., [6] employed a few oscillatory jet actuators, known as synthetic jet actuators at the rear face of the ground vehicle. Numerical simulations were performed using the Unsteady Reynolds-Averaged Navier-Stokes (URANS) equations in conjunction with a two-equation realizable k- $\epsilon$  turbulence model. The commercially available grid generator GAMBIT and the CFD solver FLUENT were employed for the simulations. Three generic ground vehicle configurations were considered in their simulations; the experimental data was available for these configurations without and with active flow control for comparison. These studies clearly demonstrated that the active flow control techniques can be employed to achieve significant reduction in aerodynamic drag of ground vehicles in range of 10–15% thus, reducing the fuel consumption between 5–7%.

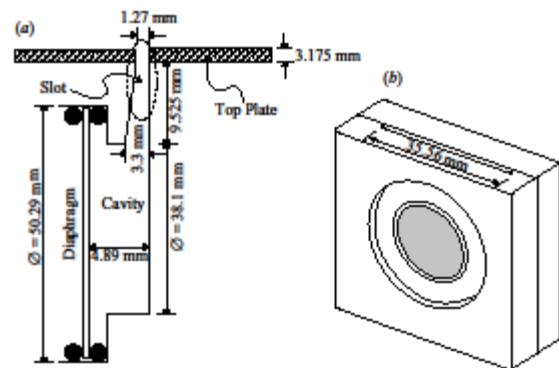

Fig. 1. (a) Cross-sectional schematic of the jet configuration used in the experiment (not to scale). The dashed oval indicates roughly the region of the jet actuator modelled in the current computations. (b) Engineering drawing of actuator geometry used in the experiment [9].

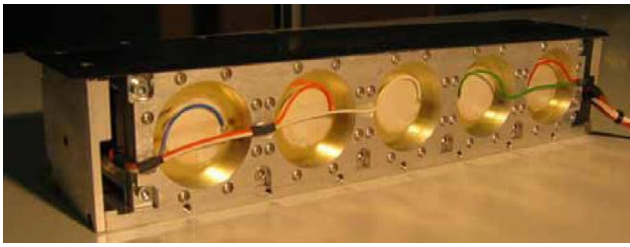

Fig. 2. Synthetic jet actuator [10]

As speed of ground vehicle increases, there are increased concerns on the aerodynamic drag reduction of ground vehicle. Recently, synthetic jet is emerging as a promising active flow control technology for aerodynamic drag reduction. Park et al. [11] performed an experimental parametric study on synthetic jet for aerodynamic drag reduction of Ahmed model. Synthetic jet array was constructed by twelve synthetic jet actuators, and installed on two kinds of Ahmed model, of which slant angles are  $25^\circ$  and  $35^\circ$ . The jets are emanated between the roof and the rear slant surface. Jet angle, momentum coefficient, and driving frequency were changed to assess the effect of synthetic jet array on aerodynamic drag. To quantify the effect of synthetic jet, the aerodynamic drag and rear surface pressure were measured and analyzed. From the result, the effect of synthetic jet actuation on aerodynamic drag differs according to the slant angle of the body. The aerodynamic drag was reduced for  $25^\circ$  slanted body, but increased for  $35^\circ$  model. In addition, jet angle, momentum coefficient, and driving frequency affect the quantity of change in aerodynamic drag [12].

The influence of rear-end periodic forcing on the drag coefficient was then investigated using electrically operated magnetic valves in an open-loop control scheme. Four distinct configurations of flow control were tested: rectangular pulsed jets aligned with the spanwise direction or in winglets configuration on the roof end and rectangular jets or a large open slot at the top of the rear slant. For each configuration, the influence of the forcing parameters (non-dimensional frequency, injected momentum) on the drag coefficient was studied, along with their impact on the static pressure on both the rear slant and vertical base of the model. Depending on the type and location of pulsed jets actuation, the maximum drag reduction was obtained for increasing injected momentum or well-defined optimal pulsation frequencies. A drag reduction of 30% was achieved, almost corresponding to the goal of automotive industry [13].

### 3.2 Active flow control with steady blowing

The design of the rear part of a car has great impact onto the vehicle's aerodynamic behavior. Lift and drag are strongly influenced by the topology of the flow in this area. The blunt body geometry of common passenger cars produces a detached, transient flow which induces fluctuating forces on the body, acting especially on the rear axle. This effect may distress dynamic stability and comfort significantly. The application of steady blowing on a realistic car model was carried out by Heinemann et al. [14] to observe its influence on the drag and lift forces on the rear portion supplied through continuous slots at positions above and beneath the rear

window. They found, the reduction of rear axle lift with active flow control was possible with small trade-off losses in drag performance. A reduction of rear axle lift by about 5% was possible with  $C_D$  changes around 1%.

Littlewood and Passmore [15] investigated the influence of steady blowing applied at a variety of angles on the roof trailing edge of a simplified  $1/4$  scale square back style vehicle. Hot-wire anemometry, force balance measurements, surface pressure measurements and Particle Image Velocimetry (PIV) were used to investigate the effects of the steady blowing on the vehicle wake structures and the resulting body forces. The energy consumption of the steady jet was calculated and was used to deduce an aerodynamic drag power change. Results show that overall gains were achieved. They concluded that the requirement for large mass flow rate limits the applicability of this technique to road vehicles.

An active flow control approach was investigated in order to reduce the aerodynamic drag of a generic square-backed vehicle. The investigations were carried out at  $Re = 5 \times 10^5$ . Large Eddy Simulation (LES) was performed as it is suitable for time dependent flows around vehicles with large coherent structures. Active flow control was applied in order to achieve drag reduction using steady blowing through small slits near the edges of the rear surface. The blowing velocity was equal to the inflow velocity ( $v_{blow} = U_0$ ), and the blowing angle was changed from  $\theta = 0^\circ$  to  $\theta = 60^\circ$ . It was shown that these control techniques can achieve a maximum drag decrease for the  $\theta = 45^\circ$  control version of around 12% [16].

A model of a generic vehicle shape, the Ahmed body with a  $25^\circ$  slant, was equipped with an array of blowing steady microjets 6 mm downstream of the separation line between the roof and the slanted rear window. The goal of the study was to evaluate the effectiveness of this actuation method in reducing the aerodynamic drag, by reducing or suppressing the 3D closed separation bubble located on the slanted surface. The efficiency of this control approach was quantified with the help of aerodynamic load measurements. The changes in the flow field when control is applied were examined using PIV, wall pressure measurements and skin friction visualisations. By activating the steady microjet array, the drag coefficient was reduced by 9-14% and the lift coefficient up to 42%, but depending on the Reynolds number [17].

Wassen and Thiele [18] investigated drag reduction of generic fastback vehicle by applying an active control with steady blowing. The actuation was applied at the rear edges of the vehicle (Fig. 3). The blowing direction was  $90^\circ$  upward at the slant edges and  $45^\circ$  inward at the edges of the vertical base. They found this approach reduced the total aerodynamic drag by 10.2%. The active control prevented the flow reattachment on the slant, leading to a significantly higher surface pressure in this area. At the same time, some adverse effects were observed which reduced the amount of drag reduction. These effects were a pressure decrease on the vertical part of the back, a pressure increase on the front, and an increase in friction drag.



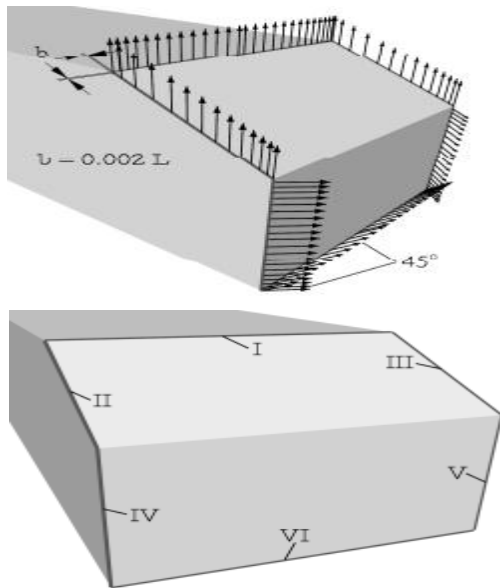

Fig. 3. Size, position and blowing direction (above) and numbering of slit segments (below) [18]

Many studies show that an active flow control provides a very good alternative prospect for reducing the aerodynamic drag on automotive vehicles. Tarakka and Simanungkalit [19] applied an active flow control of blowing in a bluff body van model adapted from modified Ahmed model which was considered the closest basic model of the family van widely produced by car manufacturer. The research was carried out by computational and experimental method. The computational approach used  $k-\varepsilon$  standard turbulence model with the objective to determine the characteristics of the flow field, the intensity of turbulence and aerodynamic drag reduction that occurred in the test model. Meanwhile, the experimental approach used load cell in order to validate the aerodynamic drag reduction obtained by the computational approach. The results showed that the addition of active control by blowing gives an influence on characteristics of the flow field, the intensity of turbulence and aerodynamic drag. Aerodynamic drag reductions close to 13.92% for computational approach and 11.11 % for experimental approach. The obtained drag reduction indicates that the flow of blowing is able to effectively reduce the wake that occurred in the back of the bluff body van model.

Method of active flow control can be applied to reduce aerodynamic drag of the vehicle as it provides the possibility to modify locally the flow, to remove or delay the separation position or to reduce the development of the recirculation zone at the back as well as the separated swirling structures around the vehicle. A passenger van was modeled with a modified form of Ahmed's body by changing the orientation of the flow from its original form (modified/reversed Ahmed Body). This model was equipped with suction and blowing on the rear side to comprehensively examine the pressure field modifications that occur in order to modify the near wall flow toward reducing the aerodynamics drag. The computational

simulation used was k-epsilon flow turbulence model. In this configuration, the front part of body was inclined at an angle of  $35^\circ$  with respect to the horizontal. The geometry was placed in a 3D-rectangular numerical domain with length, width and height equal to  $8l$ ,  $2l$  and  $2l$ , respectively. The suction and blowing velocities were set to 1 m/s, 5 m/s, 10 m/s and 15 m/s, respectively. The results show that aerodynamic drag reductions close to 15.83% for suction and 14.38% for blowing were obtained [20].

### 3.3 Active flow control with suction

Automobile aerodynamic studies are typically undertaken to improve safety and increase fuel efficiency as well as to find new innovation in automobile technology to deal with the problem of energy crisis and global warming. Some car companies have the objective to develop control solutions that enable to reduce the aerodynamic drag of vehicle and significant modification progress is still possible by reducing the mass, rolling friction or aerodynamic drag. Some flow control method provides the possibility to modify the flow separation to reduce the development of the swirling structures around the vehicle. In Harinaldi et al. [21] study, a family van was modeled with a modified form of Ahmed's body by changing the orientation of the flow from its original form (modified/reversed Ahmed body). This model was equipped with suction on the rear side to comprehensively examine the pressure field modifications that occur. The investigation combines computational and experimental work. Computational approach used a commercial software with standard k-epsilon flow turbulence model, and the objectives was to determine the characteristics of the flow field and aerodynamic drag reduction that occurred in the test model. Experimental approach used load cell in order to validate the aerodynamic drag reduction obtained by computational approach (Fig. 4). The results show that the application of suction in the rear part of the van model gives the effect of reducing the wake and the vortex formation. They found that aerodynamic drag reduction is closed to 13.86% for the computational approach and 16.32% for the experimental.

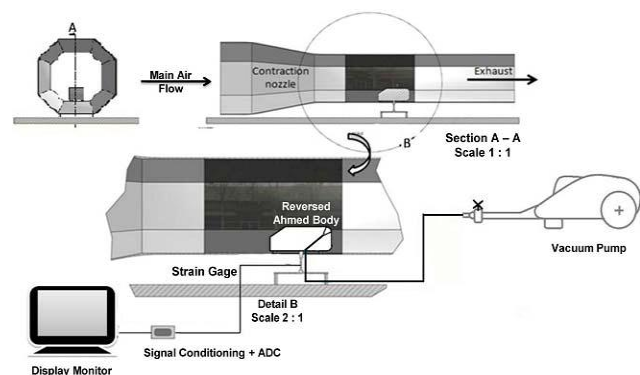

Fig. 4. Scheme of aerodynamic drag force measurement [21]

New development constraints prompted by new pollutant emissions and fuel consumption standards (Corporate Average Economy Fuel) require that automobile manufacturers develop new flow control devices capable of reducing the aerodynamic

drag of motor vehicles. The solutions envisaged must have a negligible impact on the vehicle geometry. In this context, flow control by continuous suction is seen as a promising alternative. The control configurations identified in 2D numerical analysis were adapted for this purpose and tested on a 3D geometry. A local suction system located on the upper part of the rear window was capable of eliminating the rear window separation on simplified fastback car geometry. Aerodynamic drag reductions close to 17% were obtained [22].

Aerodynamic drag is an important factor in vehicles fuel consumption. Pressure drag which is the main component of total drag is a result of boundary layer separation from vehicle surface. Jahanmiri and Abbaspour [23] experimentally investigated the effect of suction and base bleeding as two active flow control methods on aerodynamic drag reduction of Ahmed body with  $35^\circ$  rear slant angle. Suction in boundary layer was applied in order to delay flow separation by extracting flow particles with low kinetic energy near the model surface and the sucked air was blown into the wake of the model to increase the static pressure of the wake region. The location of suction is at the beginning of rear slant surface and the location of blowing is at the middle part of rear vertical part of the model. Boundary layer suction at the beginning of rear slant surface of Ahmed model can reduce the drag. However, if the suction less than  $0.0021 \text{ m}^3/\text{s}$ , it may lead to the increment of drag. This is due to the fact that weak suction intensifies the secondary flow on the rear slant surface of the model rather than affecting free stream.

Aubrun et al. [17] constructed a test facility to realistically simulate the flow around a two dimensional car shaped body in a wind tunnel. A moving belt simulator has been employed to generate the relative motion between model and ground. In a first step, the aerodynamic coefficients  $C_L$  and  $C_D$  of the model were determined using static pressure and force measurements. LDA-measurements behind the model show the large vortex and turbulence structures of the near and far wake. In a second step, the ambient flow around the model was modified by way of an active flow control which uses the Coanda effect, whereby the base-pressure increases by nearly 50% and the total drag was reduced by 10%.

#### 4. PASSIVE FLOW CONTROL

The passive control systems consist on the use of more or less discrete obstacles, added around or on the roof of the vehicle. They can be declined in two groups according to their influence on the flow control. The first group consists on obstacles positioned on the surface of the geometry. The second group consists of the obstacles positioned upstream or downstream of the geometry to be controlled [7].

##### 4.1 Passive control: Effect of VG on aerodynamic drag

A VG is an aerodynamic surface which is basically a small vane that creates a vortex. VG widely used in the aerospace industry, mainly to control boundary layer transition and to delay flow separations. A different type of VG is used on race cars for manipulating the flow over and under the

vehicle, mainly to generate down force (which is needed for better performance). Although, the effect of such VGs was studied in the past, not all features of the flow fields were documented. For example, the shape of the vortex wake behind a VG, the wake rollup and the resulting pressure signature is still not well understood. To answer the above questions (van de Wijdeven and Katz [24] studied the surface pressure distribution and the trailing vortex signature behind the VGs of a generic model in a low speed wind tunnel. The airfoil shaped VGs were tested to demonstrate the incremental effect of the vortex wake and the effect of rake (vehicle's angle of attack), was investigated as well. The results of this study provide quantitative information on the expected loads and pressure distribution behind such large-scale VGs; data needed for the successful application of such devices to actual vehicles. In order to delay the flow separation at the rear, bump-shaped VGs at the roof end of a car were tested for two different types of car models Sedan and Hatchback (Fig.5). In separate study, the aerodynamic analysis was carried out using GAMBIT and FLUENT for Sedan and Hatchback models. CFD analysis confirms that the use of VGs reduces both the drag and lift coefficients [25].

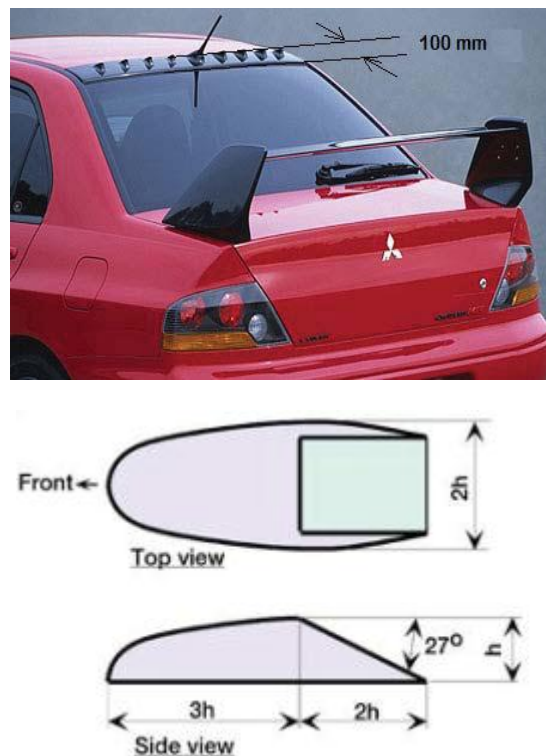

Fig. 5. Position of VG at the rear end of the roof (above) dimensions of a bump shaped VG (below) [25].

One of the main causes of aerodynamic drag for sedan vehicles is the separation of flow near the vehicle's rear end. To delay flow separation, bump-shaped VGs were tested for application to the roof end of a sedan. Commonly used on aircraft to prevent flow separation, VGs themselves create drag, but they also reduce drag by preventing flow separation

at downstream. The overall effect of VG was calculated by totaling the positive and negative effects. Since this effect depends on the shape and size of VGs, those on the vehicle roof were optimized. It was found that the optimum height of the VGs is almost equivalent to the thickness of the boundary layer (15 to 25 mm) and the optimum method of placement is to arrange them in a row in the lateral direction 100 mm upstream of the roof end at intervals of 100 mm. Based on the comparison study they found delta-wing-shaped VG is more effective than bump-shaped VG [26].

Large investments are aimed at minimizing power needed for propulsion i.e., new downsized engines with new aerodynamic devices for drag reduction. For passenger vehicles the aerodynamic drag force is the dominating resistance force at higher velocity. The vehicle body is often optimized for reducing the drag resistance. VGs belong to the category boundary layer manipulators. Their function is to reenergize an adverse pressure gradient boundary layer that is about to separate by transporting high momentum fluid from the outer part of the boundary layer down to the low momentum zone closer to the wall. Gopal and Senthilkumar [27] studied the variation of pressure coefficient, dynamic pressure, coefficient of lift and drag with and without VGs on the roof of a utility vehicle for varying yaw angles of VG. The yaw angles used are  $10^\circ$ ,  $15^\circ$  and  $20^\circ$ . To measure the effect of altering the vehicle body, wind tunnel tests have been performed with 1:15 scaled model of the utility vehicle with velocities of 2.42, 3.7, 5.42 and 7.14m/s. The experiments showed that a great improvement of the aerodynamic drag force reduction can be achieved with VG.

Reduction of the aerodynamic forces on a minivan has been achieved using a pair of pockets at the left and the right sides, respectively, of the rear roof end of the vehicle. The two pockets generate cross-streamwise vortices that cause the turbulent kinetic energy to increase in the boundary layer in the downstream of the two pockets. This increased turbulent kinetic energy induces the flow separation to be delayed further downstream along the vehicle back. Unlike the common Vortex Generators (VGs) of extrusive type, these VGs of a pocket type do not cause any additional drag by themselves [28]. Mazyan [29] numerically investigated the effect of VGs on drag. Drag reduction of 4.2% and 10% were attained for the SUV model and Ahmed car model, respectively.

#### 4.2 Passive control: Effect of spoiler on aerodynamic drag

The spoiler is used as a tool to minimize unfavorable air movement around the vehicle and can be divided into the front spoilers and the rear spoilers. A front spoiler, connected with the bumper, is mainly used to direct air flow away from the tires to the underbody. A rear spoiler is commonly installed upon the trunk lid of a passenger vehicle. The added spoiler can diffuse the airflow passing a vehicle, which minimizes the turbulence at the rear of the vehicle, adds more downward pressure to the back end and reduces lift acted on the rear trunk [30]. The rear spoiler is no longer just a decoration and

they do have measurable effect on aerodynamic drag reduction and vehicle stability [31].

The simulation of external aerodynamics is one of the most challenging and important automotive CFD applications. With the rapid developments of digital computers, CFD is used as a practical tool in modern fluid dynamics research. It integrates fluid mechanics disciplines, mathematics and computer science. With high-speed automobiles much more common nowadays, reducing the lift coefficient to enhance stability on the road is no longer just a concern for race cars. Spoilers are one of the well-known devices for producing down force on a moving vehicle. Hu and Wong [31] studied the flow around a simplified high speed passenger car with a rear-spoiler (Fig. 6) and without a rear-spoiler. The standard  $k-\epsilon$  model was selected to numerically simulate the external flow field of the simplified Camry model with or without a rear-spoiler. Through an analysis of the simulation results, a new rear spoiler was designed and it shows a mild reduction of the vehicle aerodynamics drag. This leads to less vehicle fuel consumption on the road.

Daryakenari et al. [32] studied the three-dimensional turbulent flow over both a simple car model and a real road vehicle. They found that flow pattern and the results for aerodynamic forces were in good agreement with experimental results. In addition, the same method was used to investigate the effect of numerous rear-spoilers on lift and drag coefficients of the models. They found a significant reduction in lift and drag on the models. The popular  $k-\omega$  SST turbulence model was used to assess aerodynamic forces, as well as pressure and velocity distribution.

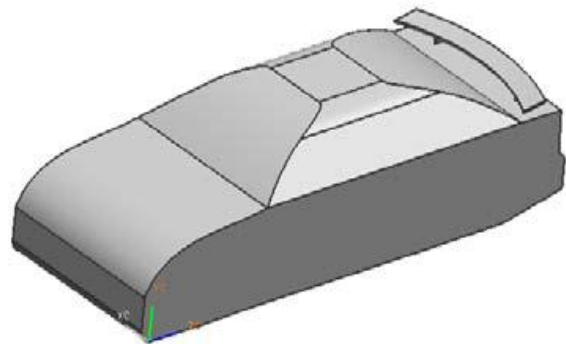

Fig. 6. 3D vehicle model with rear spoiler [31].

Kodali and Bezavada [33] carried out a similar study. They observed that, the presence of a rear spoiler reduces lift force at the back side of the car. Results show that there was considerable reduction in the coefficient of lift of around 80% with the presence of rear spoiler and a very insignificant increase in the coefficient of drag of around 3% when the vehicle was fitted with a rear spoiler. By the disturbance created in the streamline flow due to the presence of a rear spoiler, there was reduction in the flow separation at the trunk resulting in increase of turbulence. In conclusion, the study reveals that rear spoilers have considerable effect on lift, i.e.



vehicle stability and moderate effect on drag i.e. Fuel consumption.

#### 4.3 Passive control: Underbody diffuser

Mazyan [29] analyzed the effect of applying drag reducing devices on a sedan, sports utility vehicle (SUV) and a tractor trailer model to improve the fuel consumption of the vehicle. Both RANS (Reynolds-averaged Navier–Stokes equations) and LES are used to analyze the percent drag reduction due to the use of different drag reducing devices. The numerical procedure is first validated against the experimental data for the tractor-trailer model with no drag reducing devices installed. Following the validation, simulations are carried out to investigate the percent drag reduction by installing a modified front head to help the flow transition from the tractor to the trailer, and inventive rear wings that direct the air flow towards the rear of the vehicle where low pressure exists. The tractor trailer results showed a total drag reduction of around 21% when the front and rear drag reducing devices was installed. Humnic et al. [34] presented new results concerning the flow around the Ahmed body fitted with a rear underbody diffuser without endplates, to reveal the influence of the underbody geometry, shaped as a venturi nozzle, on the main aerodynamic characteristics. The study was performed for different geometrical configurations of the underbody, radius of the front section, length and the angle of the diffuser being the parameters, which were varied. Later, based on a theoretical approach, the coefficients of the equivalent aerodynamic resistances of the front section of underbody and diffuser were computed, which help to evaluate the drag due to underbody geometry.

Reducing resistance forces all over the vehicle is the most sustainable way to reduce fuel consumption. Aerodynamic drag is the dominating resistance force at highway speeds, and the power required to overcome this force increases by the power three of speed. The exterior body and especially the under-body and rear-end geometry of a passenger car are significant contributors to the overall aerodynamic drag. To reduce the aerodynamic drag it is of great importance to have a good pressure recovery at the rear. Since pressure drag is the dominating aerodynamic drag force for a passenger vehicle, the drag force will be a measure of the difference between the pressure in front and at the rear. There is high stagnation pressure at the front which requires a base pressure as high as possible. The pressure will recover from the sides by a taper angle, from the top by the rear wind screen, and from the bottom, by a diffuser. It is not necessarily the case that an optimized lower part of the rear end for a wagon-type car has the same performance as for a sedan or hatch-back car [35].

Marklund et al. [35] focused their study on the function of an under-body diffuser applied to a sedan and wagon car. The diffuser geometry was chosen from a feasibility standpoint of a production vehicle such as a passenger car. The fluid dynamic function and theory of the automotive under-body diffuser working as a drag reduction device was discussed. The flow physics of the under-body and the wake was analyzed to understand the diffuser behaviour in its

application to lift and drag forces on a vehicle in ground proximity. The results show a potential to reduce aerodynamic drag of the sedan car approximately 10%, and the wagon car by 2–3 %. The possible gain was much bigger for the sedan vehicle and the optimum occurs at a higher diffuser angle. This was most likely due to the fact that the sedan car in its original shape produced more lift force than the wagon, a wagon usually produces very little lift or even down-force. Lift forces were also reduced with the use of under-body covers with diffuser. The down-force increased, or lifts force decreased, linearly with increased diffuser angle, and the trend was the same for both sedan and wagon rear ends. Flow analysis of the wake showed the importance of how the wake is balanced.

This research aims to develop an actively translating rear diffuser device to reduce the aerodynamic drag experienced by passenger cars. One of the features of the device is that it is ordinarily hidden under the rear bumper but slips out backward only under high-speed driving conditions. Kang et al. [12] designed a movable arc-shaped semi-diffuser device, round in form, to maintain the streamlined automobile's rear underbody configuration. The device was installed in the rear bumper section of a passenger car. Seven types of rear diffuser devices whose positions and protrusive lengths and widths are different (with the basic shape being identical) were installed and Computational Fluid Dynamics (CFD) analyses were performed under moving ground and rotating wheel conditions. The main purpose of this study was to explain the aerodynamic drag reduction mechanism of a passenger car cruising at high speed via an actively translating rear diffuser device. The base pressure of the passenger car was increased by deploying the rear diffuser device, which then prevents the low-pressure air coming through the underbody from directly soaring up to the rear surface of the trunk. At the same time, the device generates a diffusing process that lowers the velocity but raises the pressure of the underbody flow, bringing about aerodynamic drag reduction. Finally, the automobile's aerodynamic drag was reduced by an average of more than 4%, which helps to improve the constant speed fuel efficiency by approximately 2% at a range of driving speeds exceeding 70 km/h.

#### 4.4 Passive control: Others add-on devices

Wahba et al. [36] numerically investigated the use of lateral guide vanes as a drag reducing device for ground vehicles (Fig. 7). Two types of ground vehicles were considered, a simplified bus model and a simplified sport utility vehicle (SUV) model. The guide vanes were used to direct air into the low-pressure wake region in order to enhance pressure recovery, which in turn would reduce form drag and hence the overall aerodynamic drag. CFD simulations were used to assess the efficiency of the drag reducing device. The steady-state simulations were based on the RANS equations, with turbulence closure provided through two-equation eddy-viscosity models. Guide vane cross-section, chord length and angle of attack were varied in order to obtain the optimal configuration for improved

aerodynamic performance. Results of simulations indicated that an overall reduction in the aerodynamic drag coefficient is up to 18% for the bus and SUV models with lateral guide vanes. Comparison with available data in the literature was carried out for validation.

Khalighi et al. [37] investigated several drag reduction devices installed in the rear of a bluff body with square back geometry in ground proximity. The experiments include drag, base pressure measurements and velocity measurements using PIV. The results of the drag and base pressure measurements show that significant reductions of the total aerodynamic drag (as high as 48%) was achieved. The results also indicated that models with base cavity have lower drag than model without it. The base pressure distributions showed a strong effect of the ground, resulting to decrease of pressure towards the lower half of the base. The devices were found to have a strong effect on the underbody flow. Rapid upward deflection of the underbody flow in the near wake was observed for the vehicle with drag reduction devices. The devices were also found to reduce the turbulent intensities in the near wake region.

Khalighi et al. [38] investigated the unsteady flow around a simplified road vehicle model with and without drag reduction devices. The simulations were carried out using the unsteady RANS in conjunction with the  $v_2$ -f turbulence model. The corresponding experiments were performed in a small wind tunnel which includes pressure and velocity fields measurements. The devices are add-on geometry parts which is a box with a cavity and boat-tail without a cavity. These devices were attached to the back of the square-back model meant to improve the pressure recovery and reduce the flow unsteadiness. They found that the recirculation regions at the base were shortened and weakened and the base pressure was significantly increased by the devices which lead to lower drag coefficients (up to 30% reduction in drag). In addition a reduction of the turbulence intensities in the wake as well as a rapid upward deflection of the underbody flow with the devices in place was observed. The baseline configuration (square-back) exhibits strong three-dimensional flapping of the wake. Comparisons with the measurements show that the simulations agree reasonably well with the experiments in terms of drag and the flow structures.

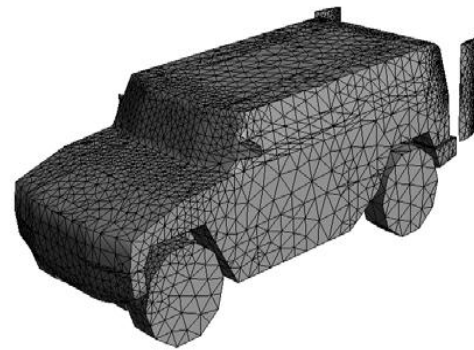
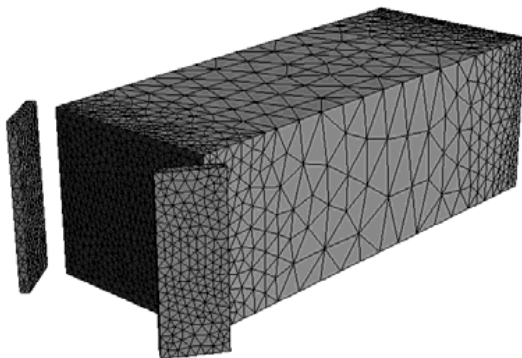

Fig. 7. Schematic with lateral guide vanes installed for (above) the box and (below) the SUV models [36]

Howell et al. [39] investigated various techniques to reduce the aerodynamic drag of bluff bodies through the mechanism of base pressure recovery. These include, for example, boat-tailing, base cavities and base bleed. In this study an Ahmed body in squareback configuration was modified to include a base cavity of variable depth, which is ventilated by slots. The investigation was conducted in free stream and in ground proximity. The results showed that, with a plain cavity, the overall body drag was reduced for a wide range of cavity depths, but a different minimum drag condition was obtained. On adding ventilation slots a comparable drag reduction was achieved but at a greatly reduced cavity depth. Pressure data in the cavity was used to determine the base drag component and showed that the device drag component was significant.

Gilliéron and Kourta [40] investigated the capacity of vertical splitter plates placed at the front or the rear of simplified car geometry to reduce drag, with and without skew angle, for Reynolds numbers between  $1.0 \times 10^6$  and  $1.6 \times 10^6$ . The geometry used was a simplified geometry to represent estate-type vehicles, for the rear section, and MPV-type vehicle. Drag reductions of nearly 28% were obtained for a zero skew angle with splitter plates placed at the front of models of MPV or utility vehicles. The results demonstrated the advantage of adapting the position and orientation of the splitter plates in the presence of a lateral wind. All these results confirm the advantage of this type of solution, and they suggested that this expertise should be used in the automotive sector to reduce fuel consumption and improve dynamic stability of road vehicles.

Fourrié et al. [41] experimentally studied a passive flow control on a generic car model. The control consists of a deflector placed on the upper edge of the model rear window. The study was carried out in a wind tunnel at Reynolds numbers based on the model height of  $3.1 \times 10^5$  and  $7.7 \times 10^5$ . The flow was investigated via standard and stereoscopic PIV, Kiel pressure probes and surface flow visualization. The aerodynamic drag was measured using an external balance and calculated using a wake survey method. Drag reductions up to 9% were obtained depending on the deflector angle. The deflector increases the separated region on the rear window. The results show that when this separated region is wide



enough, it disrupts the development of the counter-rotating longitudinal vortices appearing on the lateral edges of the rear window. They suggested that flow control on such geometries should consider all the flow structures that contribute to the model wake flow.

Various vehicles have been designed as short blunt bodies. Drag coefficients of these bodies are high because adverse pressure gradients cause boundary layer separation from their surfaces, but a reduction of the size of separation zone allows for a substantial reduction of the body drag. It can be done via displacement of their boundary layer separation far downstream. Such displacement was achieved with a passive flow control. Rohatgi [42] built and tested a small scale model (length 1710 mm) of General Motor SUV in the wind tunnel under expected wind conditions and road clearance for two passive devices namely rear screen, it is plate behind the car and rear fairing where the end of the car is aerodynamically extended (Fig.8). It was found that rear screen could reduce drag up to 6.5% and rear fairing can reduce the drag by 26%. However the implementation of any drag reduction options was limited by aesthetic and practical considerations of vehicle. Sharma and Bansal [43] evaluated the drag coefficient of passenger car that was installed with the tail plate (Fig.9). They found that the addition of tail plates results in a reduction of the drag-coefficient 3.87% and lift coefficient 16.62% in head-on wind. They made a conclusion that the drag force can be reduced by using add on devices on vehicle leading to fuel economy and improving stability of a passenger car.

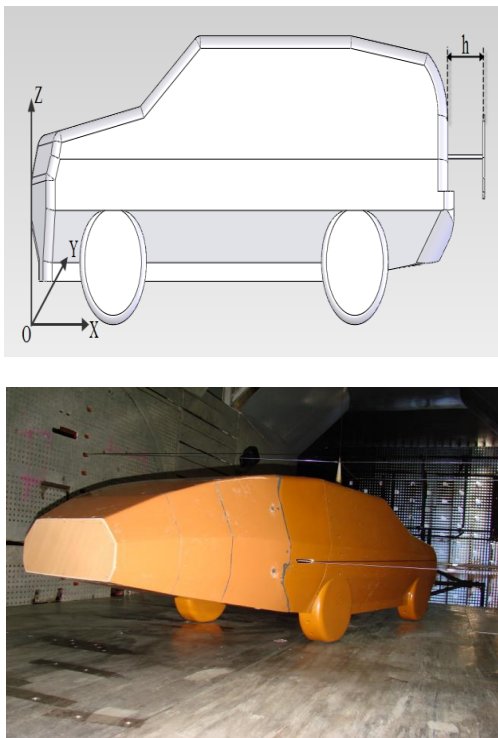

Fig. 8. Vehicle model with side view of rear screen (above) and four-section rear fairing (below) [42].

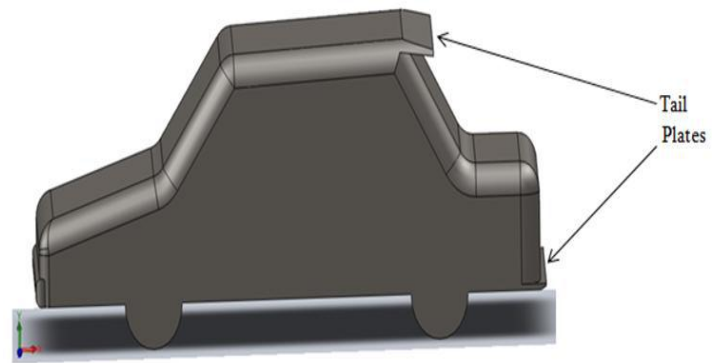

Fig. 9. Passenger car with tail plates [43].

#### 4.4 Passive control: body streamline

The Ahmed body is used as a reference model for fundamental studies of car-type bluff body aerodynamics, in particular focused on the influence of the rear slant angle on the drag coefficient. Conan et al. [44] carried out study to obtain reliable drag coefficient comparable to the literature and explained the nature of the flow over Ahmed body when the rear slant angle was changed from  $10^\circ$  to  $40^\circ$ . The drag coefficients were measured in both an open and a closed test sections differ by less than 0.5% which proves the reliability and reproducibility of the results. The sensitivity of the drag coefficient to some parameters such as the model roughness or the oncoming boundary layer and the lack of precise information on these parameters in the literature could explain the difference observed with the Ahmed drag coefficient data. The various types of measurement techniques were used in this study underline for complementarily. The combination of PIV and oil visualization provides a deeper understanding of the flow behaviour around the Ahmed body and a physical interpretation of the drag coefficient evolution.

Separation on the rear end of an Ahmed body was suppressed by means of coherent streamline streaks forced on the roof of the model. These streaks originate from an array of suitably shaped cylindrical roughness elements and were amplified by the mean shear through the lift-up effect. Interacting with the mean velocity field at leading order, they induce a strong controlled spanwise modulation. The resulting streaky base flow was observed to sustain the adverse pressure gradient since PIV measurements as well as static wall pressure distributions show that the re-circulation bubble completely vanishes. These modifications of the topology of the flow were associated with a substantial drag reduction, which can be of about 10% when the roughness array was optimally placed on the roof of the bluff body [45].

The separated flow past the square-back model used in the experiments of Ahmed et al. [46] is controlled using flaps at the end of the top and bottom faces. Grandemange et al. [47] performed a parametric study of the flow regarding the slant angle of the flaps from pressure and force measurements as well as PIV. When the bottom flap orientation was fixed, variations in the top slant angle indicate a quadratic dependence of drag versus lift. This relationship presents self-similarities when modifying the bottom flap angle. It was

furthermore observed that the lift was an affine function of both slant angles and the drag was a second-order polynomial containing a coupling term between the two angles. The evolution of the drag, depending on both angles, was discussed. The contribution of the wake size, lift-induced drag as well as the local drag induced by the inclination of the flaps was interpreted.

Drag and lift forces plays a vital role in the performance and stability of vehicles. Less drag means less fuel consumption and hence less vehicular pollution. Also, lower lift force means higher chance of adhesion of the car body with the ground causing less overturning of the vehicle, which improves the vehicle performance. Both drag and lift forces can be manipulated by varying the ground clearance of the cars in experimental study. Mitra [48] studied the effect of ground clearance on these aerodynamic forces experimentally. The result revealed that increase in ground clearance will increase drag and decrease lift. Therefore, optimization to obtain the best ground clearance is required.

Doost [49] carried out aerodynamic analysis to observe the flow lines, vortex generated around the car and the pressure distribution on the vehicle structure. Later on the area that increases the drag force was identified that providing idea to reduce the drag force. The ideas were to channel air from the front bumper to rear bumper transfer leading to reduce the air pressure in front of the vehicle and reduction in the vortex behind the car was covered in foam equipment. The proposed design reduces drag coefficient by 23%, directly improving fuel consumption in vehicles. This remarkable save in fuel provides reduction in air pollution and brings about a green environment.

## 5. DESIGN OPTIMIZATION FOR DRAG REDUCTION

Song et al. [50] proposed an aerodynamically optimized outer shape of a sedan by using an Artificial Neural Network (ANN), which focused on modifying the rear body shapes of the sedan. To determine the optimization variables, the unsteady flow field around the sedan driving at very fast speeds was analyzed by CFD simulation, and fluctuations of the drag coefficient ( $C_D$ ) and pressure around the car were calculated. After consideration of the baseline result of CFD, 6 local parts from the end of the sedan were chosen as the design variables for optimization. Moreover, an ANN approximation model was established with 64 experimental points generated by the D-optimal methodology. As a result, an aerodynamically optimized shape for the rear end of the sedan in which the aerodynamic performance was improved by about 5.64% when compared to the baseline vehicle was proposed. Finally, it was expected that within the accepted range of shape modifications for a rear body, the aerodynamic performance of a sedan was enhanced so that the fuel efficiency of the sedan was improved.

The rear geometry of a passenger car has the most significant influence on its aerodynamic characteristics. Ghani [51] studied the aerodynamic shape optimization of the rear geometry of passenger cars. The Non-uniform rational B-spline (NURBS) curve was used to represent the rear body of

a generic passenger car model (the Ahmed Body) and the NURBS parameters were employed for geometry parameterization. These geometry parameters were systematically modified using design of experiments to obtain different geometries of the simplified car model. The computational fluid dynamics (CFD) simulations were performed on these geometries to obtain drag coefficients. Once the results of CFD simulations were available, a response surface model was constructed using linear regression technique. Finally, the design exploration was performed using the response surface model instead of actual CFD simulations. This technique resulted in a radical simplification of the design process as the behavior of the aerodynamic drag was predicted using a simple polynomial. The proposed methodology was implemented to perform design exploration of a generic fast back model. The response surface model was able to predict the aerodynamic drag coefficients within an error of 5%. Aerodynamic shape optimization was also performed on a generic notch back model using the response surface technique and the optimized geometry parameters for minimum drag were obtained in only 18 iterations. On the basis of the results, it can be concluded that the proposed methodology is inexpensive, simple and robust. It can therefore provide the basic framework for the design and development of low drag passenger cars.

In the recent times, CFD simulations, with the advent of computer architectures with superfast processing capabilities are rapidly emerging as an attractive alternative to conventional wind tunnel tests which are either too restrictive or expensive, for aerodynamic styling of a car. In vehicle body development, reduction of drag is essential for improving fuel consumption thus protects the global environment and driving performance, and if an aerodynamically refined body is also aesthetically attractive, it will contribute much to increase the vehicle's appeal to potential customers. Islam and Mamun [52] outlined the process taken to optimize the geometry of a vehicle. Vertices and edges were imported into Gambit and a computational domain created. An unstructured triangular mesh was then applied. The CFD program Fluent was used to iterate toward a converged solution with the goal of obtaining a better flow around the car and drag force. The results were analyzed and only the drag force was compared with a recognized journal to validate the results.

## 6. COUPLE FLOW CONTROL METHODS

Several couple control techniques were used to reduce the drag coefficient of the square back Ahmed body. Bruneau et al. [13] carried out an investigation to show the possibility to couple passive and active control techniques to improve the flow control. Based on their study, a drag reduction of 30% was achieved though this combination. Kim et al. [53] used the distributed forcing to reduce drag on a two-dimensional model vehicle. The forcing (blowing and suction) was applied at the upper and lower trailing edges, and is steady in time but varies sinusoidally in the spanwise direction. Both the LES (LES) and wind-tunnel experiment were carried out. LES was performed at the Reynolds number ( $Re$ ) = 4200, whereas

Re=20 000 and 40 000 were considered in the experiment. It was shown that a significant base-pressure recovery (i.e. drag reduction) was obtained with the present distributed forcing under LES, together with a substantial suppression of vortex shedding in the wake behind the model vehicle. Similar results were also obtained from the experiment at higher Reynolds numbers, indicating that the present distributed forcing for drag reduction is applicable to a two-dimensional bluff body at various Reynolds numbers. Brunn et al., [54] investigated the drag reduction on generic fastback vehicle with the application of active control approaches which is a combination of steady blowing and suction. Blowing and suction was done through an array of small slits along the vehicle's upper rear edge reduced the drag by 9.4%. The active control increased the average pressure both on the slant and on the vertical base of the car model which had a slant angle of  $25^\circ$ . On the slant, the area of separated flow was significantly reduced, while on the vertical base the size of the recirculation bubble increased. The advantage of this approach is that there is no net mass flux, so that it can work locally without any long tubing system

A flow-control study using steady suction and pulsed blowing in close proximity was conducted on an axisymmetric bluff body at length-based Reynolds numbers between 1.0 and  $4.0 \times 10^6$ . The study included a coupled incremental computational-fluid-dynamics and experimental approach. It began with computations of various model setup designs. Subsequently, flow-control experiments and computations were used to optimize steady suction alone. Finally, flow control was provided by a synchronized array of 28 suction and oscillatory blowing actuators, positioned slightly upstream of the baseline separation. Results show suction alone has a limited ability to delay separation and reduce drag on this geometry. Suction located far from the baseline separation is shown to actually increase drag. Addition of pulsed blowing enables separation delay to the trailing edge and drag to be nullified. Increased overall system efficiency, including estimated total actuator power invested, was found at low momentum input for optimally located steady suction and pulsed blowing. This was partially attributed to the particular geometry used because the active flow-control system shows a robust ability to delay separation. Not all measured trends were predicted by computation due to the complex nature of this configuration and the active flow-control system characteristics [55].

For high speed passenger cars, the aerodynamic pressure drag is predominant due to the flow separation particularly on the rear window and on the wheel base. One of the main causes of aerodynamic drag for passenger cars is the separation of flow near the vehicle's rear end. Large energy losses are often associated with boundary layer separation. The main design goal of a 'rear spoiler' in passenger vehicles is to reduce drag at its rear and thereby increasing fuel efficiency. The present investigation is focused on flow control by vortex generators (VG) in combination with the rear spoiler. A test facility is developed to realistically simulate the flow around a geometrically similar, 15:1 reduced

scale PoP clay model of a high-speed SEDAN car tested in wind tunnel. A total of 26 combinations are tested for the car model by changing the flow angles, spoiler angles and orientations of vortex generators (co-rotating and counter-rotating). A marked improvement in static pressure along the car roof, especially at the car rear is noticed at a flow angle  $-30^\circ$  by subsequent use of rear spoiler at angle  $= +45^\circ$  and co-rotating vortex generators. It can be seen in that in general, the surface pressure coefficients are positive and reasonably uniform over the windward face (the side facing the airflow) of the car. It is also observed that suction is present on the roof of the vehicle, and this suction tend to increase from the front to rear of the vehicle. The best combination in terms of pressure coefficient rise (by over 92%) was found while the car is facing wind at a flow angle of  $0^\circ$  and is combined with spoiler at an angle of  $0^\circ$  with co-rotating vortex generators attached at the upstream of the spoiler ( $x/L = 0.733$ ). For the car with flow angle = 0 degree and with a rear spoiler at angle  $= +45^\circ$ , combined with the co-rotating orientation of the VG lined in series, it gives the best performance by reducing the drag coefficient value with an impressive 68.18% [56].

## 7. SUMMARY

The classification of flow control methods and the performance of these methods to reduce drag coefficient reported in the reviewed papers is summaries in Table I.

Table 1  
Summary of flow control methods and its performance in reducing drag coefficient

Type of control	Flow control method	Percentage of Drag coefficient reduction and reference
Active	A strip of pulse jets	20% [8]
	Synthetic jet	8.5%[10],(10-15%[6]
	Steady blowing	5%[14], 12%[16],9-14%[17], 10.2[18] 11.11-13.92%[19], 14.38%[20], 50% [38],
	Suction	15.83[20], 13.86-16.32%[21],17%[22],10%[17]
Passive	Vortex generator	4.2-10%[28]
	Rear spoiler	3%[33]
	Diffuser	21%[29],10%[35], 4% [12]
	Guided vanes	18% [36]
	Base cavity	48% [37]
	Vertical splitter plate	28% [40]
	Deflector	95 [41],
	Rear screen	6.5% [42]
	Rear fairing	26% [42]
	Tail plate	3.87% [43]
	Streaks (a array of cylindrical roughness elements)	10% [45]



## 8. CONCLUDING REMARKS

- The aerodynamic drag of a road vehicle is responsible for a large part of the vehicle's fuel consumption and contributes up to 50% of the total vehicle fuel consumption at highway speeds. Reducing the aerodynamic drag offers an inexpensive solution to improve fuel efficiency.
- Conventional passive control techniques, consisting in modifying the shape of the vehicle or attaching add-on devices to reduce the aerodynamic drag, appears as the easiest to implement but unfortunately it only dedicated for particular application. Due to wide range of applications active flow control is preferable. However both methods proved to be able to reduce aerodynamic drag of vehicle thus have potential for fuel economy.
- A large contribution to the aerodynamic drag of a vehicle arises from the failure to fully recover pressure in the wake region, especially on square back configurations. A degree of base pressure recovery can be achieved through careful shape optimisation, but the freedom of an automotive aerodynamicist to implement significant shape changes is limited by a variety of additional factors such styling, ergonomics and loading capacity.
- The review provides information on the methods that could be possibly used to improve fuel efficiency and as guidance for aerodynamic design.
- The relative effectiveness of flow control methods (between active methods) or (between passive methods) is not known as the percentage of drag reduction was compared with base model of vehicle as it is different between the experiments.
- The selection of mathematic model of flow, Reynolds number, vehicle model, design parameters, forcing parameters need for further investigation as it influences the result of aerodynamic drag.

## ACKNOWLEDGEMENT

The authors would like to thank Universiti Teknikal Malaysia Melaka (UTeM) for the technical and financial support under short term grant scheme (PJP/2012/FKM (46C)/S01051).

## REFERENCES

- [1] Krishnani, P. N. (2009) CFD study of drag reduction of a generic sport utility vehicle, *Master's Thesis*, Mechanical Engineering Department, California State University, Sacramento.
- [2] Hucho, W. H. and Sovran, G. (1993) Aerodynamics of road vehicles, *Annual Review of Fluid Mechanics*, Vol. 25(1), pp485-537.
- [3] Mayer, W., and Wickern, G. (2011) The new audi A6/A7 family-aerodynamic development of different body types on one platform, *SAE International Journal of Passenger Cars-Mechanical Systems*, Vol. 4(1), pp197-206.
- [4] Chainani, A. and Perera, N. (2008) CFD Investigation of airflow on a model radio control race car, *WCE 2008*, 2-4July, London.
- [5] Wood, R.M. (2004) Impact of advanced aerodynamic technology on transportation energy consumption. *SAE Technical Paper 2004-01-1306*.
- [6] Bellman, M., Agarwal, R., Naber, J., and Chusak, L. (2010) Reducing energy consumption of ground vehicles by active flow control. In *ASME 2010 4th International Conference on Energy Sustainability*, pp 785-793, American Society of Mechanical Engineers.
- [7] Kourta, A., and Gilliéron, P. (2009) Impact of the automotive aerodynamic control on the economic issues, *Journal of Applied Fluid Mechanics*, Vol.2(2), pp69-75.
- [8] Bideaux, E., Bobillier, P., Fournier, E., Gilliéron, P., Hajem, M., Champagne, J. Y., and Kourta, A. (2011) Drag reduction by pulsed jets on strongly unstructured wake: towards the square back control, *International Journal of Aerodynamics*, Vol.1(3), pp282-298.
- [9] Kotapati, R. B., Mittal, R., & Cattafesta III, L. N. (2007) Numerical study of a transitional synthetic jet in quiescent external flow. *Journal of Fluid Mechanics*, Vol.581, pp287-321.
- [10] Kourta, A., and Leclerc, C. (2013) Characterization of synthetic jet actuation with application to Ahmed body wake, *Sensors and Actuators A: Physical*. 192, pp13-26.
- [11] Park, H., Cho, J. H., Lee, J., Lee, D. H., and Kim, K. H. (2013) Aerodynamic drag reduction of Ahmed model using synthetic jet array, *SAE International Journal of Passenger Cars-Mechanical Systems*, Vol 6(1), pp1-6.
- [12] Kang, S. O., Jun, S. O., Park, H. I., Song, K. S., Kee, J. D., Kim, K. H., and Lee, D. H. (2012) Actively translating a rear diffuser device for the aerodynamic drag reduction of a passenger car, *International Journal of Automotive Technology*, Vol.13(4), pp583-592.
- [13] Bruneau, C. H., Creusé, E., Depeyras, D., Gilliéron, P., & Mortazavi, I. (2010) Coupling active and passive techniques to control the flow past the square back Ahmed body, *Computers & Fluids*, Vol.39(10), pp1875-1892.
- [14] Heinemann, T., Springer, M., Lienhart, H., Kniesburgers, S., and Becker, S. (2012) Active flow control on a 1:4 car model, In *16th Int Symp on Applications of Laser Techniques to Fluid Mechanics* Lisbon, Portugal, 09-12 July.
- [15] Littlewood, R. P., and Passmore, M. A. (2012) Aerodynamic drag reduction of a simplified squareback vehicle using steady blowing, *Experiments in fluids*, Vol. 53(2), pp519-529.
- [16] Eichinger, S., Thiele, F., and Wassen, E. (2010) LES of active separation control on bluff bodies by steady blowing, *FEDSM-ICNMM2010-30462*, pp.1055-1063.
- [17] Aubrun, S., McNally, J., Alvi, F., and Kourta, A. (2011) Separation flow control on a generic ground vehicle using steady microjet arrays, *Experiments in fluids*, Vol.51(5), pp1177-1187.
- [18] Wassen, E., and Thiele, F. (2010) Simulation of active separation control on a generic vehicle, In *at: 5th AIAA Flow Control Conference*, Chicago, USA.
- [19] Tarakka, R., and Simanungkalit, S. P. (2013) Effect of active control by blowing to aerodynamic drag of bluff body van model, *International Journal of Fluid Mechanics Research*, Vol.40(4), pp312-323.
- [20] Harinaldi, Budiarso, Tarakka, R. and Simanungkalit, S.P. (2011) Computational analysis of active flow control to reduce aerodynamics drag on a van model, *International Journal of Mechanical & Mechatronics Engineering IJMME-IJENS*, Vol. 11(3), pp24-30.
- [21] Harinaldi, B., Warjito, E. A. K., and Rustan Tarakka, S. P. S. (2012) Modification of flow structure over a van model by suction flow control to reduce aerodynamics drag. *Makara Seri Teknologi*, Vol. 16(1), pp15-21.
- [22] Rouméas, M., Gilliéron, P., and Kourta, A. (2009) Drag reduction by flow separation control on a car after body, *International Journal for Numerical Methods in Fluids*, Vol. 60(11), pp 1222-1240.
- [23] Jahanmiri, M., and Abbaspour, M. (2011) Experimental investigation of drag reduction on ahmed model using a combination of active flow control methods, *International Journal of Engineering-Transactions A: Basics*, Vol.24(4), pp403-410.
- [24] van de Wijdeven, T., & Katz, J. (2014) Automotive application of VGs in ground effect, *Journal of Fluids Engineering*, Vol. 136(2), 021102.
- [25] Dubey, A., Chheniya, S., and Jadhav, A. (2013) Effect of Vortex generators on Aerodynamics of a Car: CFD Analysis. *International*

- Journal of Innovations in Engineering and Technology (JIJET)*, Vol. 2(1), pp137-144.
- [26] Koike, M., Nagayoshi, T., and Hamamoto, N. (2004) Research on aerodynamic drag reduction by VGs, *Mitsubishi Motors Technical Review*, No. 16, pp11-16.
- [27] Gopal, P., and Senthilkumar, T. (2012) Aerodynamic drag reduction in a passenger vehicle using vortex generator with varying yaw angles, *ARPN Journal of Engineering and Applied Sciences*, Vol.7(9), pp1180-1184.
- [28] Kim, I., and Chen, H. (2010) Reduction of aerodynamic forces on a minivan by a pair of vortex generators of a pocket type, *International journal of vehicle design*, Vol.53(4), pp300-316.
- [29] Mazyan, W. I. (2013) Numerical simulations of drag-reducing devices for ground vehicles, *Doctoral dissertation*, American University.
- [30] Che Zakem, R. (2008) Aerodynamics of aftermarket rear spoiler, *Bachelor Thesis*, Universiti Malaysia Pahang.
- [31] Hu, X. X., and Wong, T. T. (2011) A numerical study on rear-spoiler of passenger vehicle, *World Academy of Science, Engineering and technology*, Vol. 57, pp636-641.
- [32] Daryakenari, B., Abdullah, S., Zulkifli, R., Sundararajan, E., and Sood, A. M. (2013) Numerical study of flow over Ahmed body and a road vehicle and the change in aerodynamic characteristics caused by rear spoiler, *International Journal of Fluid Mechanics Research*, Vol.40(4), pp354-372.
- [33] Kodali, S. P., and Bezavada, S. (2012) Numerical simulation of air flow over a passenger car and the Influence of rear spoiler using CFD, *International Journal of Advanced Transport Phenomena*, Vol. 01(1), pp.6-13.
- [34] Huminic, A., Huminic, G., and Soica, A. (2012) Study of aerodynamics for a simplified car model with the underbody shaped as a venturi nozzle, *International Journal of Vehicle Design*, Vol.58(1), pp15-32.
- [35] Marklund, J., Lofdahl, L., Danielsson, H., and Olsson, G. (2013) Performance of an automotive under-body diffuser applied to a sedan and a wagon vehicle, *SAE International Journal of Passenger Cars-Mechanical Systems*, Vol. 6(1), pp293-307.
- [36] Wahba, E., Al-Marzooqi, H., Shaath, M., Shahin, M., and El-Dhmarshawy, T. (2012) Aerodynamic drag reduction for ground vehicles using lateral guide vanes, *CFD Letters*, Vol.4(2), pp68-79.
- [37] Khalighi, B., Balkanyi, S. R., and Bernal, L. P. (2013) Experimental investigation of aerodynamic flow over a bluff body in ground proximity with drag reduction devices, *International Journal of Aerodynamics*, Vol.3(4), pp217-233.
- [38] Khalighi, B., Chen, K. H., and Iaccarino, G. (2012) Unsteady aerodynamic flow investigation around a simplified square-back road vehicle with drag reduction devices, *Journal of Fluids Engineering*, Vol.134(6), 061101.
- [39] Howell, J., Sims-Williams, D., Sprot, A., Hamlin, F., and Dominy, R. (2012) Bluff body drag reduction with ventilated base cavities, *SAE International Journal of Passenger Cars-Mechanical Systems*, Vol.5(1), pp152-160.
- [40] Gilliéron, P., and Kourta, A. (2010) Aerodynamic drag reduction by vertical splitter plates, *Experiments in Fluids*, Vol.48(1), pp1-16.
- [41] Fourrié, G., Keirsbulck, L., Labraga, L., and Gilliéron, P. (2011) Bluff-body drag reduction using deflector, *Experiments in Fluids*, Vol.50(2), pp385-395.
- [42] Rohatgi, U. S. (2012), Methods of reducing vehicle aerodynamic drag, *ASME 2012 Summer Heat Transfer Conference*, Puerto Rico, USA, July 8-12.
- [43] Sharma, R. B., and Bansal, R. (2013) CFD simulation for flow over passenger car using tail plates for aerodynamic drag reduction, *IOSR Journal of Mechanical and Civil Engineering (IOSR-JMCE)*, Vol. 7, No. 5, pp 28-35.
- [44] Conan, B., Anthoine, J., and Planquart, P. (2011) Experimental aerodynamic study of a car-type bluff body, *Experiments in Fluids*, Vol.50 (5), pp1273-1284.
- [45] Pujals, G., Depardon, S., and Cossu, C. (2010) Drag reduction of a 3D bluff body using coherent streamwise streaks, *Experiments in Fluids*, Vol.49(5), pp1085-1094.
- [46] Ahmed, S.R., Ramm, G. and Faltin, G. (1984) Some salient features of the time averaged ground vehicle wake, *SAE Technical Paper Series*, 840300.
- [47] Grandemange, M., Mary, A., Gohlke, M., and Cadot, O. (2013) Effect on drag of the flow orientation at the base separation of a simplified blunt road vehicle, *Experiments in Fluids*, Vol.54 (5), pp1-10.
- [48] Mitra, D. (2010) Design optimization of ground clearance of domestic cars, *International Journal of Engineering Science and Technology*, Vol. 2 (7), pp 2678-2680.
- [49] Doost, A. K. (2013) Green nature and reducing of air pollution with vehicle drag coefficient correction, *Advances in Energy Engineering*, Vol. 1(2), pp 28-33.
- [50] Song, K. S., Kang, S. O., Jun, S. O., Park, H. I., Kee, J. D., Kim, K. H., & Lee, D. H. (2012) Aerodynamic design optimization of rear body shapes of a sedan for drag reduction, *International Journal of Automotive Technology*, Vol.13(6), pp905-914.
- [51] Ghani, O. A., (2013) Design optimization of aerodynamic drag at the rear of generic passenger cars using nurbs representation, *Master Thesis*, University of Ontario Institute of Technology.
- [52] Islam, M. M. and Mamun, M. (2010) Computational drag analysis over a car body, *Proceedings of MARTEC 2010 The International Conference on Marine Technology, 11-12 December, Dhaka, Bangladesh*.
- [53] Kim, J., Hahn, S., Kim, J., Lee, D. K., Choi, J., Jeon, W. P., and Choi, H. (2004) Active control of turbulent flow over a model vehicle for drag reduction, *Journal of Turbulence*, Vol.5(019), pp1-12.
- [54] Brunn, A., Wassen, E., Sperber, D., Nitsche, W., & Thiele, F. (2007) Active drag control for a generic car model, In *Active Flow Control*, pp. 247-259, Springer Berlin Heidelberg.
- [55] Wilson, J., Schatzman, D., Arad, E., Seifert, A. and Shtendel, T. (2013) Suction and pulsed-blowing flow control applied to an axisymmetric body, *AIAA Journal*, Vol. 51(10), pp. 2432-2446. doi: 10.2514/1.J052333
- [56] Sagar, D., Paul, A. R., Upadhyay, R. R., and Jain, A. (2010) Aerodynamic effects of rear spoiler and vortex generators on passenger cars, *ICTACEM-2010/311*.